

PRO LIFTING TOWERS

Using & installation user manual

WT 500



WT 500

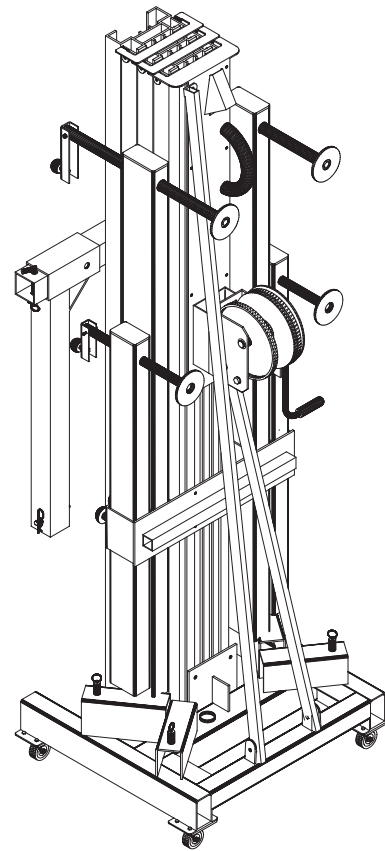
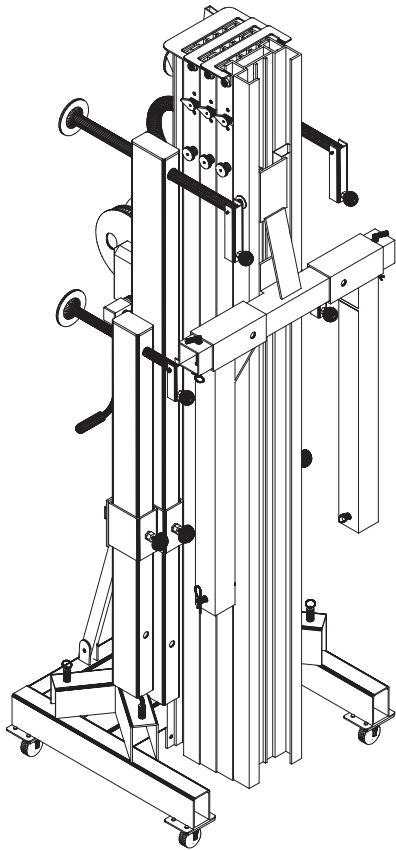

INTRODUCTION	1
FEATURES	2
SPECIFICATIONS	2
FASTENER SYSTEM	3
(VER.12.04) NEW BLOCKING SYSTEM	3
SAFETY RULES	4
INSTALLING THE LIFTING TOWER	8
PLACING THE LOAD	9
WINCH OPERATION (Special Care)	10
LIFTING PROCESS	11
DESCENT/FOLDING PROCESS	12
CONFORMITY DECLARATION	13
BGV C1, EXPLANATION & TEST	14

INTRODUCTION

WT 500 is a lifting tower for LINE ARRAY systems composed of 4 extensible aluminium reinforced sections. This new profile system can elevate heavy loads (270 kg) at high altitude (5.98 m). Making it very suitable for all types of events. The ground reinforcement system has been thoroughly studied, giving the tower legs subjection of great length and stabilizing slopes. The Line Array bracket system has been strengthened taking into account the force exerted and the thickness of metal walls and clamping rings have been increased by incorporating angled finish allows support equitable loads.

As usual in **WORK** products, all components have been oversized with the goal of achieving a superior security:

- Autoblocking system.
- Additional profile blocking system when transporting.
- Bubble level indicator vial.
- 2 iron braces placed in the back side for additional reinforcement.
- Strong security cable made of steel under DIN standard.
- Exclusive blocking system with high resistance and able to ensure the whole firmness.

FEATURES

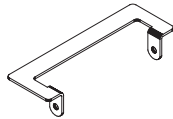

Upper reinforcing piece in each section to avoid deformations with high loads.



Double blocking system:
 - For transportation (upper pin bolt)
 - Folding/unfolding (lower pin bolt).



Iron braces placed in the back side for additional reinforcement.

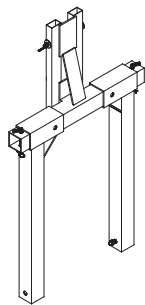

SopORTE horizontal para elevar la carga acoplada.

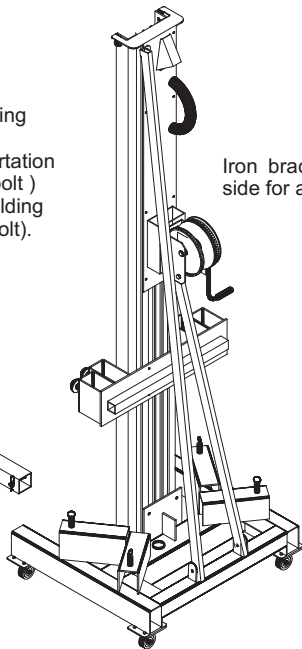
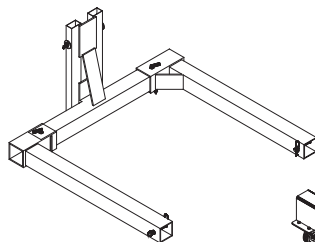

SPECIFICATIONS

	MAX LOAD (KG)	MIN LOAD (KG)	UNFOLDED LIFTER		FOLDED LIFTER		WEIGHT (KG)
			HEIGHT (M)	BASE (M)	HEIGHT (M)	BASE (M)	
WT 500	270	30	5,98	1,93 x 1,75	1,96	0,55 x 0,56	152

	CABLE						WINCH	
	COMPOS. (GALVANIZED)	Ø (mm)	RESIST. (N / mm2)	LOAD (KN - KP)	WEIGHT/Mtr (KG/M)	ROLL.	BOBBING CAPACITY (M.)	REDUCT. RANGE
WT 500	7 x 19+1	7	1770	28.8 - 2930	0,187	CROSSED TO RIGHT	48	3.75 : 1

MODEL	STANDARDS & REGULATIONS
WT 500	DIN 15020 / VGB 1 / VGB 8

FASTENER SYSTEM

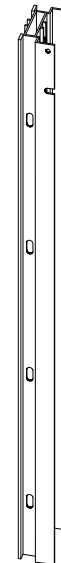

This system uses a profile especially designed to heavy loads. the width of these profiles and the wall thickness, ensure a great firmness of the assembly. They incorporate a lane with fixing holes which houses safety pins. these holes are large enough so that the pins introduced easily and quickly providing a fast deployment of the tower.

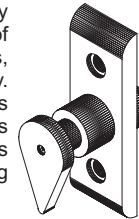

Safety pins have been oversized, both in diameter as the piston as the main safety part. the lock/unlock system is performed exerting a small flip and rotate, allowing this operation so simple and complete security.

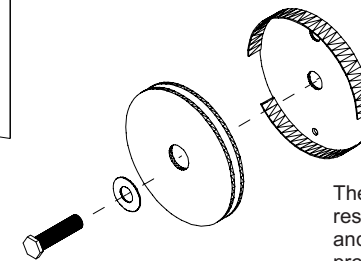

The pulley system (which raised or lowered each profile), is responsible for transmitting the stress generated in the winch and raise each section, for this reason, these pulleys have a proper design to handle the wire, covering the entire system in a compact assembly.

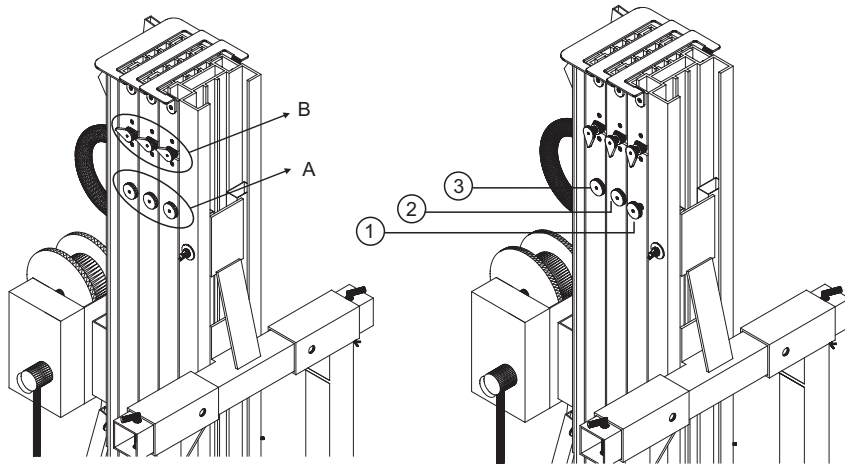

INTRODUCTION

New V.1204 blocking system applied to **WT 500 & LW 476 R**, incorporates two security blocking systems.

The first system (**marked as A**) allows to block the profiles to transport or block a profile individually.

The second system (**marked as B**) is an automatic trigger, unblocking it, allowing to deploy or undeploy the profile, blocking it in the prefixed fixation position.

OPERATION

1. All triggers must be in block position for transport.
2. When the lifter will be placed in position and secured with the legs, block all triggers for automatic system (**marked as B**) and unblock the most external trigger for the first system (**marked as 1**).
3. Using the winch, we will ONLY deploy the first profile. This profile will be blocked in the first prefixed position, if we want to deploy more, act over the winch and the profile will be deployed automatically until the next prefixed position. During deploying process, the automatic system (marked as B) will be blocking/unblocking in the inner holes placed in the profile, becoming in an additional security system.
4. Once reached the desired position of the first profile, BLOCK again the trigger of the first system (**marked as 1**).
5. Now, repeat the process with the next trigger of the first system (**marked as 2**), unblocking it to deploy the associated profile.
6. Repeat all process until deploying all profiles.

UNDEPLOYED

1. Repeat the process in inverse way. Unblock the trigger **marked as 3**, the associated profile will descend until reaching the stand position. In this moment, **BLOCK** the trigger **marked as 3**.
2. Now, proceed in similar way with the next trigger (**marked as 2**)
3. Repeat this process until reaching the stand position of the whole lifter.
4. **CHECK** as all trigger of **system A** are blocked and **BLOCK** all trigger of **system B** to transport the lifter.

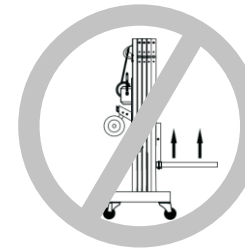

Do not elevate the tower without using the stabilize legs.

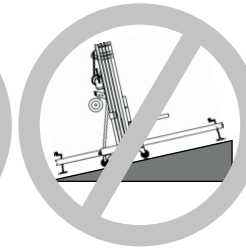
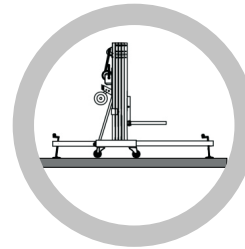

Place the tower over a flat and stable surface. Do not install it in a place where the use over the stabilize leg would not be enough to reach a perfect balance.

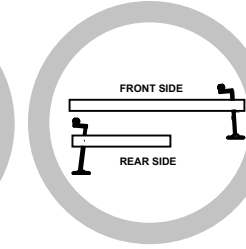
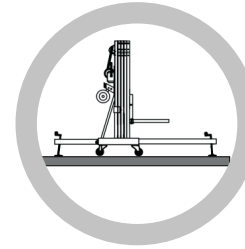

The two largest legs must be placed in the frontal tower side and the shortest ones at both winch sides.

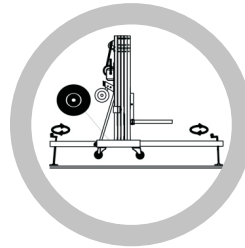

Act individually over the stabilize leg up to the wheels lose contact with the ground and ensuring a perfect balance of the tower. This balance will be showed in the vial.



Do not move away the stabilizer legs after the load is elevated.

SAFETY RULES

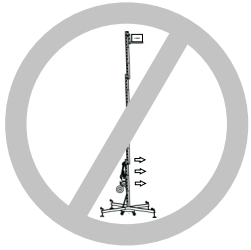

Do not move the tower after the load is elevated



Do not lean elements (like stairs, platforms, scaffoldings, etc.) over the tower which can make pressure over it and to destabilize

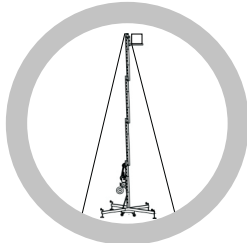

For outdoor installations ensure the tower with security tights to ground. NEVER fix them to surfaces with oscillations like structures, etc.

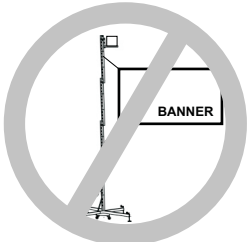

Do not use the tower like support for banners or decorative support. With heavy wind, these elements could act as "sail" and to knock over the tower.



Do not use the tower in heavy wind conditions. Take into account that if the exposed height and surface is maximum, the tower stability is reduced.

SAFETY RULES

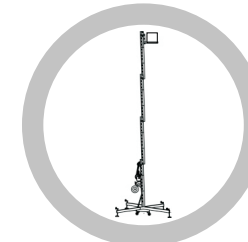

The load must be firmly placed over the support the nearest possible gravity center of the tower, in order to facilitate its balance.



Do not overload the tower beyond the max. weight recommended in the manufacturer specifications.

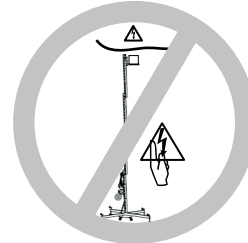

In the moment you elevate the tower, check that it does not take contact with elements or objects which with the tower could hit or come off.

Be aware specially with the electrical conductions, due to the towers are not electrically isolated, it can represent a serious electric shock danger.



Do not stay down to the tower after the tower elevation nor elevation or folding process.



This tower is not designed to elevate persons. Do not use it for a different purpose that it has been designed

SAFETY RULES

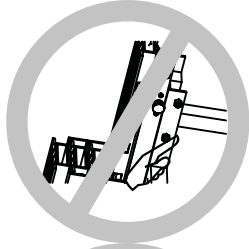

Keep the hands and fingers moved away to mobiles elements of the towers like profile unions.



Do not lubricate the brake system of the winch, the mechanism could lose efficiency.

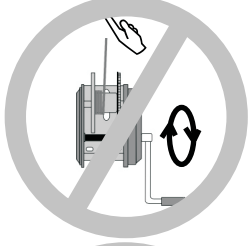

Do not catch the cable during the elevation or folding process.

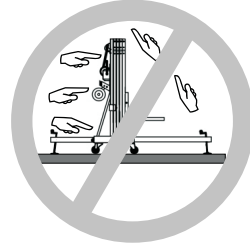

Avoid the non-desired tower manipulation by non-qualified people.



Check periodically the good winch conditions of the and cable security. In order to guarantee the security cable integrity, consult the section about the winch operation.



NOT TAKE INTO CONSIDERATION THESE RULES COULD CAUSE THE KNOCK OVER OF THE TOWER OR ITS LOAD, PROVOCATING DAMAGES IN PEOPLE AND PROPERTIES

INSTALLING THE LIFTING TOWER

Place the tower over a flat and stable surface to install the tower, discarding its use over rolling platforms or surfaces which would be able to bear as much its own weight as coupled load.

The installation area must be free of debris, stone, etc. that reduce the firmness of the tower at ground.

Moreover the tower must no be placed near elemenst which can obstruct the vertical folding process like balconies, cornices, etc.

Be aware specially with the proximity of electric cables which the tower could take or crimp them. Consider that the tower is not electrically isolated, so, it can be load with electricity and to constitute a serious electric shock risk.

The tower disposes of two sets of legs with different length in order to settle the tower. Remove them for the transport support in order to insert them.

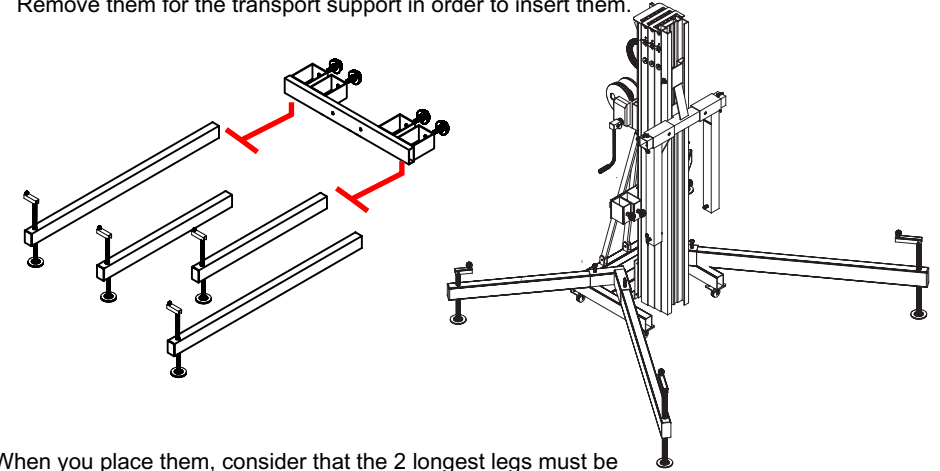

When you place them, consider that the 2 longest legs must be placed in the frontal side of the tower and the shorter ones in both sides of the winch frontal side of the tower and the shorter ones in both sides of the winch.

The longest legs placed in the frontal side.

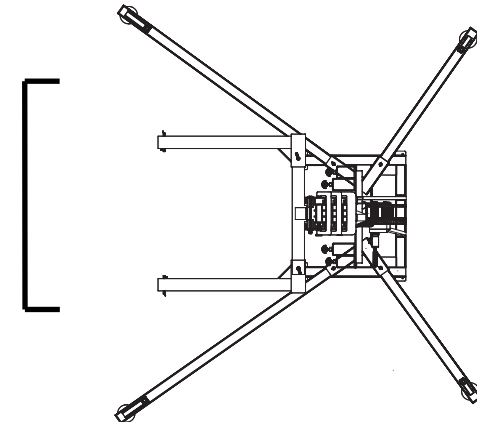

INSTALLING THE LIFTING TOWER

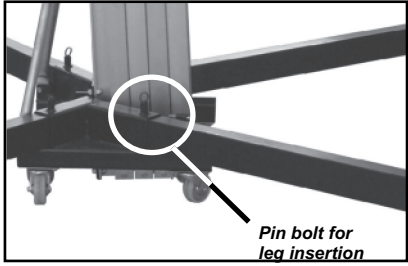

In order to insert the legs, use corresponding pin bolt and insert the leg to correct position triggering the bolt. To ensure the set stability.

Pin bolt for leg insertion

Rotate the crank of the stabilizer placed on each legs up to the wheels located in the base do not touch the ground. During this process, control the vial in order to act individually over each stabilizer up to obtain a perfect balance.

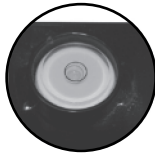

Vial for level control

DISTRIBUYENDO LA CARGA

Once the tower will be balanced and fixed to the ground, you can proceed to place the load on the incorporate support.

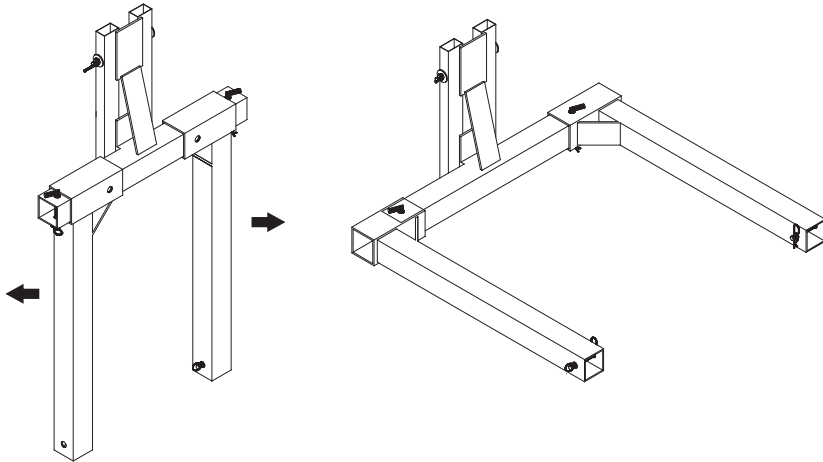

Support in stand position for transport. Extract the pin bolts and place it in horizontal position in order to locate the load.

WINCH OPERATION (Special Care)

During the tower elevation process, pay attention to the cable rolling. This cable must be coiled in parallel turns around the winch cylinder NEVER MUST BE PRODUCED CABLE CROSSES IN DIFFERENT DIRECTIONS.

In this way, that cable can be endangered or got worn, causing, at the end, the break of the cable.

If any spiral is rolled in this way, turn the winch in opposite sense up to release of wrong turn. Then, proceed to coil again in an appropriated way

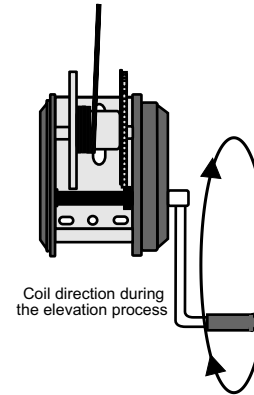

CORRECT MODE

Coil direction during the elevation process

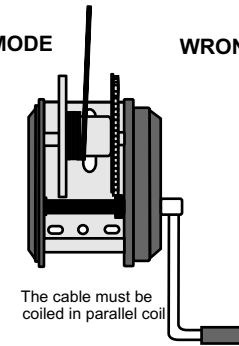

WRONG MODE

The cable must be coiled in parallel coil

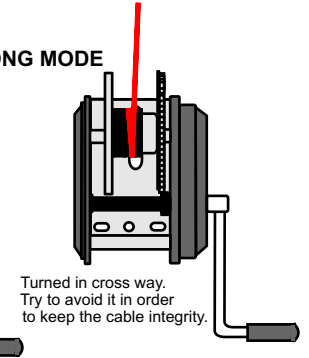

Turned in cross way. Try to avoid it in order to keep the cable integrity.

LIFTING PROCESS

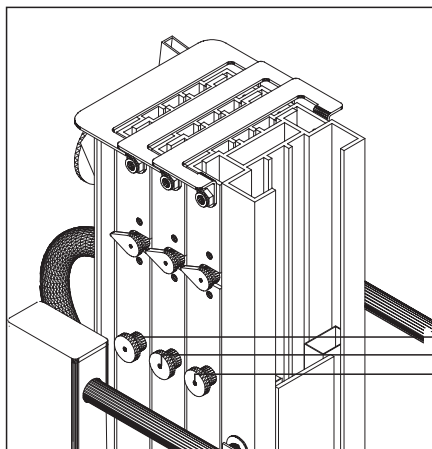

1. When the lifter is in the required position, secured with the legs and attached with the front support to attach the load horizontally, is the time to raise the load coupled.
2. Block ALL the locking pins for transportation (**A system**).
3. Unblock the most external safety pin (**marked 3**) in **B system**.

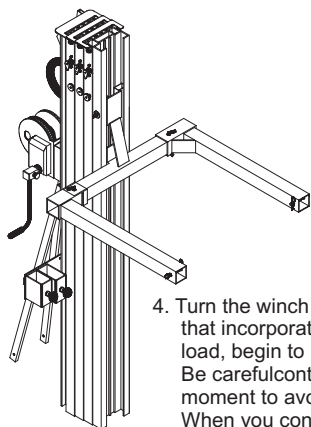

4. Turn the winch clockwise, the profile that incorporates the support with the load, begin to rise. Be careful controlling load in each moment to avoid oscillations. When you consider that the profile is in the correct position, block the pin (**marked 3**) again and continue turning the winch. The pin will be inserted into the next hole of the lane.

PIN BOLT FOR TRANSPORTATION (A System)

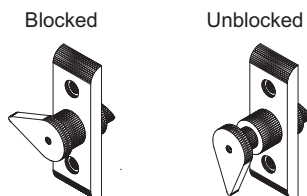

SAFETY PIN BOLT (B System)

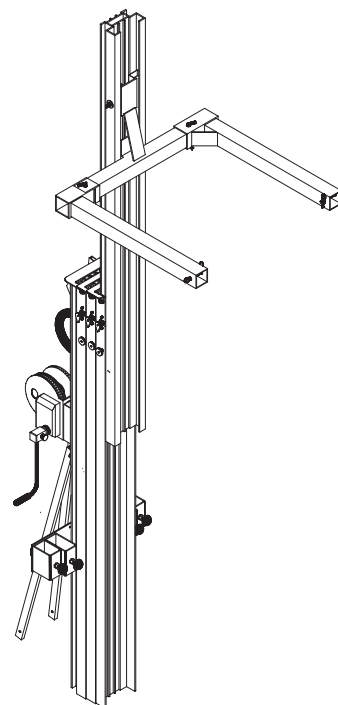
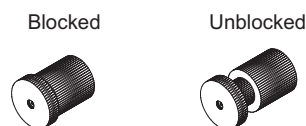

LIFTING PROCESS

5. Continue deploying the profiles unblocking the pin security of the next segment (**marked as 2**), proceeds equally with the winch. Once you reach the approximate height required, block the pin, now, rotating the winch a few more turns, is inserted into one of the holes of the rail.
6. Finally, deploy the last profile, unblocking the last pin (**marked as 3** and proceed in the same way as points 4 and 5.
7. The lifter is fully deployed as shown in the drawing on the right.

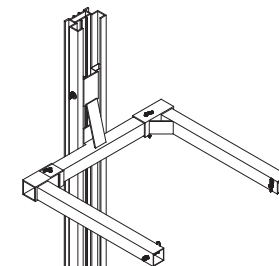

DESCENT/FOLDING PROCESS

1. For the lifter descent / folding process, proceed in reverse way. For this, unblock the last pin (**marked as 3**) and turn the winch counterclockwise carefully to avoid load oscillations, which may be higher due to the height. Once this section reaches the rest position, re-block this pin (**marked as 3**).
2. Now we have to descend the next profile. Perform the same operation, unblock the pin (**marked as 2**) for the associated profile. Once fully down the profile, block again the pin (**marked as 2**).
3. Finally, proceed with the first profile unblocking the pin (marked as 1) and rotating the winch until the complete folding of the section. Re-block the pin (**marked as 1**).
4. Remove the load of the horizontal support.
5. Place the horizontal support arms in the transport position.
6. Block ALL transport pins (**A system**)
7. Remove front and rear legs and insert them into their accommodation.
8. Now the lifter is ready for transport.

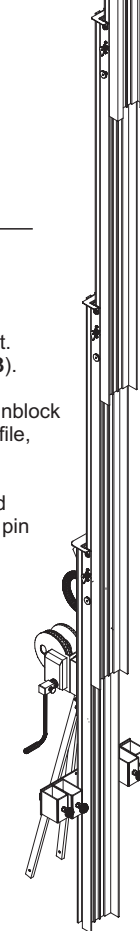

CONFORMITY DECLARATION

The described Truss-Lifts meets all the requirements specified in the Directive 2006/42/EC of the European Parliament and the Council of 17 May 2006 on machinery, and amending Directive 95/16/EC.

Applicant : **EQUIPSON, S.A**
Address : Avda. El Saler, 14 Pol. Industrial L'Alteró
46460 SILLA - Valencia (Spain)
Representative : **EQUIPSON, S.A**
Address : Avda. El Saler, 14 Pol. Industrial L'Alteró
46460 SILLA - Valencia (Spain)
Description : Lifts for Truss Systems

WORK® LW 465 R
WORK® LW 480 R
WORK® WT 600



Juan José Vila
(Product Manager)
October 22, 2009



The test report was carried out from the submitted type-samples of a product in conformity with the specification of the respective standards. The certificate holder has the right to fix the CE-mark on the product complying with the inspection samples.

BGV C1 REGULATION, Explanation

BGV C1 is a regulation for Staging and Production Facilities for the Entertainment Industry. Lifting and rigging equipment is just part of this standard and cover structures and other technical matters.

Adopting

BGV C1 is entirely voluntary (except in Germany) but its adoption is generally required by insurance companies and therefore it has effectively become an industry standard.

The application of this standard over lifting towers is vital due to in theatres, stages, etc. are used to move loads over performers and, in some cases, above spectators, representing a potential falling risk.

BGV C1 REGULATION, Application fields

This standard is orientated in two ways:

By one side, the lifting towers adopt designs and materials in order to achieve a high security degree in magnitudes like load supported, balance, friction resistance, etc.

So a **WORK®** lifting tower **BGV C1** certified ensures the customer that has passed strict test during its design, materials choice or load and effort verifications.

By other side, in order to achieve an optimum operation with these units, is recommended as much a responsible use of the unit, complying basic rules like maximum load accepted or tower balance as maintenance periodic, which must be carried by expert technicians, checking the good state of the steel cable and winch, operation of the safety bolts and folding/unfolding of the entire profile system.

BGV C1, TESTS & CHECKS

MODEL SERIAL NUMBER

INITIAL CHECK (First year)

Checked by

Date

Signature

Tested elements and conclusions

FOUR YEARS TEST

Checked by

Date

Signature

Tested elements and conclusions

ANNUAL TEST (passing the fourth year)

Checked by

Date

Signature

Tested elements and conclusions

ANNUAL TEST (passing the fourth year)

Checked by

Date

Signature

Tested elements and conclusions

ANNUAL TEST (passing the fourth year)

Checked by

Date

Signature

Tested elements and conclusions



www.worklifters.com

EQUIPSON, S.A. Avda. del Saler, 14 - Pol. Ind. L'Alteró (Silla) - 46460 Valencia- Spain- Tel. +34 96 121 63 01 - Fax +34 96 120 02 42 - equipson@equipson.es/www.equipson.es